

R Series (20K-48K) Condensing Units

Seawater-Cooled Condensers With Reverse-Cycle Heating



Available in capacities from 20,000 to 48,000 BTU/hr, Type R remote condensing units represent the next generation of seawater-cooled, reverse-cycle heat pumps for cooling and heating in marine applications. Models up to 36,000 BTU/hr use reciprocating compressors, while the 48K units use scroll compressors.

These condensing units can be installed with up to two Cruisair cooling units, where the total cooling unit capacity is equal to the condensing unit capacity. Some applications may allow three cooling units on one condenser; contact the Cruisair Applications department for assistance in design, prior to installation. In the cooling mode, full performance is available in seawater up to 90°F (32°C). In reverse-cycle heating, the unit will provide heat in seawater as low as 40°F (4.4°C).

The high-efficiency compressors deliver full capacity at lower amperages. The newly designed, one-piece electrical box with 3 ft. (0.9 m) cable can be remote mounted simply by removing one screw (RN models have a secondary box). Additional service ports allow ease of charging and servicing. The one-piece chassis/pan has two drain locations, and hold-down brackets secure all four corners, allowing easier installation and removal. The Type R condenser is designed as a drop-in for the older F type, with few modifications.

R type units are designed for installation in the vessel's engine room or other mechanical space. The unit is not affected by moisture, normal vibration, or ambient temperatures up to 140°F (60°C). No ventilation is required.

Three different series of Type R units are available, depending on what type of control is desired. Standard R units utilize the SA3 3-knob rotary switch assembly, RX units are controlled by the SMX II microprocessor, and RN models use SMX Net microprocessors. The SMX units include the respective SMX II or SMX Net power/logic boards. In addition, an SMXir or the new SMXht keypad/display, a CXP connecting cable, and a TSEP temperature sensor must be purchased separately. If networking RN units, CNP network cables are also needed.

Key Benefits

- Higher efficiency compressors at lower amperages
- Service ports on refrigerant lines and base valves
- Compressor vibration-isolation mounts minimize noise and vibration
- Condensate drain pan with front and rear drain stems
- Environmentally safe R-417A refrigerant
- Condensate drain pan with front and rear drain stems
- Corner mounting brackets for easier installation
- High- and low-pressure switches
- Electrical box can be mounted remotely
- Optional seawater coil manifolds
- Additional vibration isolation kit available
- Charged, tested, and leak checked at the factory

Cruisair[®]

by Dometic GROUP

Specifications for R Series (20K-48K) Condensing Units

Model ⁽¹⁾⁽²⁾⁽³⁾	R*20				R*24				R*30				R*36				R*48											
Capacity (BTU/h)	20000				24000				30000				36000				48000											
Voltage (V) ⁽⁴⁾	230	220	230		220	380	230		220	230		220	230		220	460	380	230		220		460	380					
Cycle (Hz)/Phase (Ph)	60/1	50/1	60/1	60/3	50/1	50/3	60/1	60/3	50/1	60/1	60/3	50/1	60/3	50/3	60/1	60/3	50/1	60/3	50/3	60/1	60/3	50/1	60/3	50/3				
Full Load Amps (FLA) Cool (A) ⁽⁵⁾	5.9	5.3	7	4.8	6.9	3.2	7.7	5.9	8.7	9.2	7.1	9.8	3.5	4	11.3	8.7	12.4	4.3	5.5									
Full Load Amps (FLA) Heat (A)	7.4	6.6	8.6	6.2	8.5	4.1	9.6	6.6	10.6	11.6	7.9	12	4	5.1	16.6	11.3	17.3	5.7	6.5									
Locked Rotor Amps (LRA) (A)	48	55	60	58	55	30	61	58	70	73	68	76	36	42	104	93	133	48	60									
Max. Circuit Breaker (A)	30		35		25		30		10		40		25		35		45		30		40		15		60	45	60	20
Min. Circuit Ampacity (A)	18	19	22	15	19	8	24	17	22	28	15	24	10	11	39	25	38	12	14									
Refrigerant Type	R417A				R417A				R417A				R417A				417A R417A											
Max. Height (in/mm)	16.75/426				16.75/426				16.75/426				16.75/426				16.75/426		16.936/431		16.75/426							
Width (in/mm)	15.75/401				15.75/401				15.75/401				15.75/401				15.75/401											
Depth-With Elec. Box (in/mm)	20.875/531				20.875/531				20.875/531				20.875/531				20.875/531											
Depth-Without Elec. Box (in/mm)	18.75/477				18.75/477				18.75/477				18.75/477				18.75/477											
Seawater Inlet Connection (in/mm)	5/8 /16				5/8 /16				5/8 /16				5/8 /16				5/8 /16											
Refrigerant Line Connection-Discharge (in/mm)	3/8 /10				3/8 /10				3/8 /10				3/8 /10				3/8 /10											
Refrigerant Line Connection-Suction (in/mm)	1/2 /13				1/2 /13				3/4 /20				3/4 /20				3/4 /20											
Height-Electrical Box (in/mm) ⁽⁶⁾	16.54/421				16.54/421				16.54/421				16.54/421				16.54/421											
Width-Electrical Box (in/mm)	9/229				9/229				9/229				9/229				9/229											
Depth-Electrical Box (in/mm) ⁽⁷⁾	3.67/94				3.67/94				3.67/94				3.67/94				3.67/94											

¹ "M" is the designator for type of control. For mechanical controls, replace "M" with "M". For SMX Net replace with "N", indicate "X" for SMX II and use "Q" for Q-Logic.

² For a specific voltage, add the following after the capacity designator: 'C' for 230V/60Hz/1-Phase, 'CK' for 220-240/50Hz/1-Phase, 'D' for 230V/60Hz/3-Phase, 'E' for 460V/60Hz/3-Phase, and 'ECK' for 380V/50Hz/3-Phase. Adding nothing will indicate 115V/60Hz/1-Phase (not available for multi-ton models).

³ For information about voltages not shown in this sheet, please contact Dometic Marine sales at 954-973-2477.

⁴ Some 60Hz equipment can be operated in a 50Hz environment but at a 17% decrease in capacity. Full-rated capacity can be obtained by specifying Cruisair "CK" (220V/50Hz) equipment.

⁵ Compressor starting current will vary with voltage but is approximately 3 to 4 times the full-load amps.

⁶ Height shown is for electrical box with Q-Logic (RQ models) and SMX II (RX models) control systems. Height with mechanical control (RM models) is 16.20 in. (412 mm); with SMX Net (RN models) the height is 16.58 in. (422 mm).

⁷ Depth shown is for electrical box with Q-Logic control system (RQ models). Depth with SMX II control (RX models) is 3.70 in. (94 mm); with SMX Net control (RN models) the depth is 7.16 in. (182 mm); with mechanical control the depth is 3.63 in. (93 mm).

Dimensions

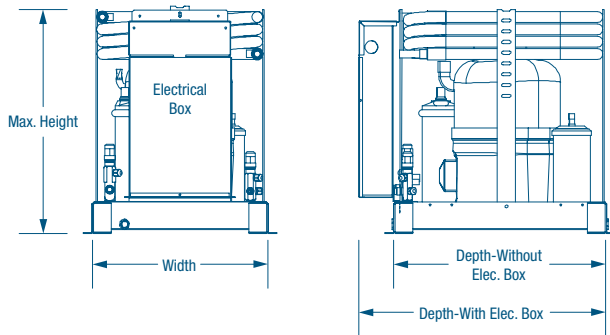

NOTE: Drain fittings extend 1/4 in. (7 mm) from front and back of pan.

DOMETIC MARINE DIVISION

2000 N. Andrews Ave. Ext. | Pompano Beach, FL 33069 USA | Tel. 954-973-2477 | Fax: 954-979-4414
www.Dometic.com/Marine | MarineSales@DometicUSA.com

24/7 TECH SUPPORT FOR UNITED STATES & CANADA:

8:00 AM to 5:00 PM Eastern Time: 800-542-2477
After hours and weekends: 888-440-4494

INTERNATIONAL SALES & SERVICES

Europe & the Middle East: Call +44(0)870-330-6101
For all other areas visit our website to find your nearest distributor.

Dealer

