

Elite™ Display

With Passport I/O Microprocessor Control System



Elite keypad/display shown with Vimar® Eikon bezel (sold separately)

The Elite™ display provides easy-to-use climate control in an attractive, modern package. It works with Marine Air's Passport I/O microprocessor-based system for the precise control and monitoring of marine air conditioning systems. Passport I/O operates at 115 or 230 volts, each operable at 50 or 60 cycles.

The Elite display features raised buttons for easy access and control. The Mode button is used to scroll through the four modes of operation, simplifying programming. Decorative snap-on Vimar® bezels (sold separately) are available in a variety of colors and materials to match your vessel's interior.

Passport I/O is flash programmable, which allows for future software upgrades without the need to replace the circuit board. A ground shield protects against static interference and RF noise, and the circuit board is conformally coated to provide high resistance to external damage or corrosion. A display cable with modular jacks connects the panel to the system controller. Non-volatile memory stores all user-selectable parameters indefinitely during operation and through any power-failure situations.

The Passport I/O circuit board utilizes state-of-the art SMT technology and has an optional integrated CAN-bus network adapter that provides ship-wide network monitoring of multiple DX systems and air handlers. The adapter adheres to CAN-bus Standard 2.0B and is fully ISO compliant. It is available in two high-level CAN-bus communication protocols to support connection to several popular helm and cabin touchscreen control systems.



Elite keypad/display shown with Vimar® Idea bezel in gold (sold separately).

Key Benefits

- Automatic humidity control reduces moisture when the boat is unattended
- Cool-only, heat-only, dehumidify, and automatic mode selection
- New optional electric-heat relay
- Optional CAN bus adapter puts cabin control on the ship-wide network
- Displays Fahrenheit and Celsius
- Automatic or manual fan-speed selection
- Cycle fan with compressor or continuous fan operation
- Cycle pump with compressor or continuous pump operation
- Compressor time delay staging for multiple unit applications
- Dimmable display
- Controls shaded pole and split capacitor fan motors
- Compressor fail-safe protection
- Programmable de-icing cycle
- Built-in air sensor
- Optional remote air sensor
- Available with popular Vimar bezels, including the Eikon (sold separately)

Specifications for Elite™ Display

Model	ELITE (VIMAR IDEA BEZEL)	ELITE (VIMAR EIKON BEZEL)
Set Point Temp. Range (°F/°C)	65 - 85/18.4 - 29.5	65 - 85/18.4 - 29.5
Display Temp. Range (°F/°C)	5 - 150/-15 - 65.6	5 - 150/-15 - 65.6
Air-Sensor Temp. Range (°F/°C)	5 - 150/-15 - 65.6	5 - 150/-15 - 65.6
Sensor Accuracy (°F/°C)	2/77/-16.7/25	2/77/-16.7/25
Water Inlet Sensor Cable Length (AH-Elite) (ft/m)	7/3	7/3
Display Cable Length (ft/m - ft/m) ⁽¹⁾	10/3.1 - 75/22.9	10/3.1 - 75/22.9
Optional Alternate/Remote Air Cable Length (ft/m) ⁽¹⁾	7 - 60/2.2 - 18.3	7 - 60/2.2 - 18.3
Optional Outside Air-Sensor Cable Length (ft/m) ⁽¹⁾	7 - 50/2.2 - 15.3	7 - 50/2.2 - 15.3
Optional Pump Sentry Cable Length (ft/m)	7 - 60/2.2 - 18.3	7 - 60/2.2 - 18.3
Water Inlet Sensor Cable Length (AH-Elite) (ft/m)	7 - 60/3 - 19	7 - 60/3 - 19
Height-Display (in/mm)	2.96/76	2.88/74
Width-Display (in/mm)	4.41/113	4.45/114
Depth-Display (in/mm)	1.08/28	1.05/27
Panel Cut-Out Height (in/mm)	2.19/56	1.88/48
Panel Cut-Out Width (in/mm)	3.31/85	2.75/70
Height-Bezel (in/mm) ⁽²⁾	2.96/76	3.31/85
Width-Bezel (in/mm)	4.41/113	4.69/120

¹ Maximum length is 75 ft. (23 m).

² Bezels sold separately, dimensions may vary depending on style.

Electrical Specifications for Passport I/O Control System

Voltage	Cycle	Compressor Output ⁽¹⁾	R.V. Output ⁽³⁾	Fan Output	Heater Output	Pump Output ⁽²⁾
115 or 230	50 or 60Hz	40V	0.25V	6V	30/20V	1/4 HP (0.2KW) 1/2 HP (0.4KW)

¹ Maximum loads should not exceed 85% of listed output ratings.

² Does not apply to AH-Elite or AH-Passport (for chilled water systems).

³ Used as water valve output for AH-Elite and AH-Passport (for chilled water systems).

Dimensions

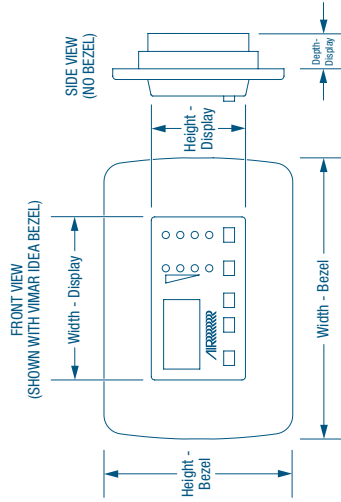

DOMETIC MARINE DIVISION

2000 N. Andrews Ave. Ex. | Pompano Beach, FL 33069 USA | Tel. 954-973-2477 | Fax: 954-979-4414
 www.Dometic.com/Marine | MarineSales@DometicUSA.com

24/7 TECH SUPPORT FOR UNITED STATES & CANADA:

8:00 AM to 5:00 PM Eastern Time: 800-542-2477
 After hours and weekends: 888-440-4494

INTERNATIONAL SALES & SERVICES

Europe & the Middle East: Call +44(0)870-330-6101
 For all other areas visit our website to find your nearest distributor.

L-2237 Rev. 2014/09/26

Specifications and availability subject to change without notice.



Installation

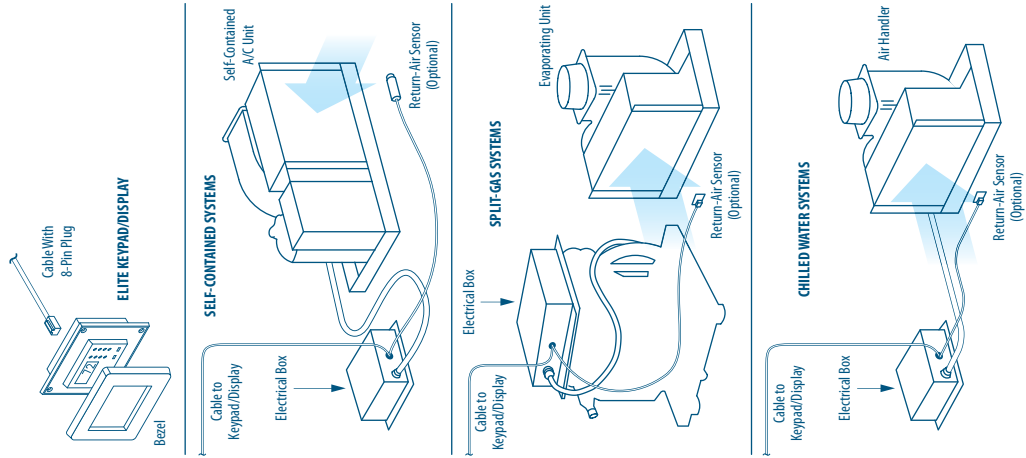

Dealer